

Dome reference ×××	Trip Force±20(g)			Trip Force±30(g)	
	80	160	200	250	280
Height H±0.05(mm)	0.25	0.29	0.31	0.32	
Click ratio(%)±15	60				

REVISIONS HISTORY				精度	公差
REV	DESCRIPTION	DATE	MODIFIED BY	CLASS	TOLERANCE
				X.X	±0.30
				X.XX	±0.10
				X.XXX	±0.05
				ANGLES	±0.5°

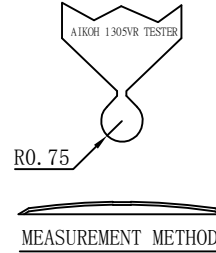
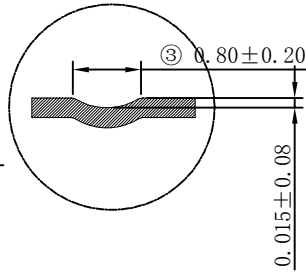
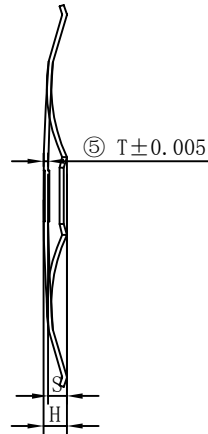
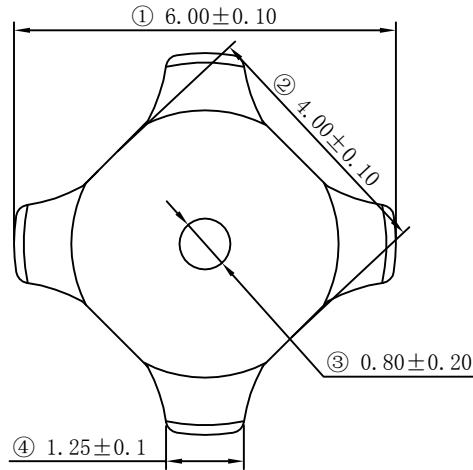

寿命测试规范:

Specification for life testing

测试头为直径2.0mm铜质平头, 打击力度为2倍之
Copper, 2.0mm cylinder flat head, Hit force is 2 times
弹片标准荷重规格 (超过250gf的弹片规格, 打击力度选择
standard Froce specification (Over 250gf, Hit force
500gf), 打击位置为弹片正中心,
500gf). Right in the center of the Dome.

打击速度为120次/分, 测试治具底部为平面;
Speed:120cycles/min, Height of fixture: 0mm

YY	Plating	Thickness
DN	Nickel	0.2um
DJ	Gold	0.05um
DY	Silver	0.5um

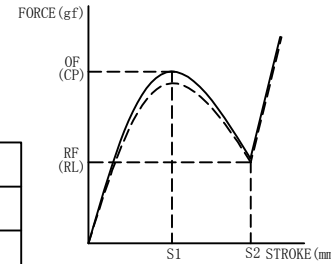

FORCE CHARACTERISTICS

OF: OPERATING FORCE (gf)
CP: COMPRESSION PEAK POINT
RF: RETURN FORCE (gf)
RL: RELEASE LOW POINT
S: STROKE (mm)
CR: CLICK RATIO
CR= [(OF-RF)/OFx100%]
RESISTANCE: ≤1Ω

麦拉PET+锅仔总高度=产品厚度 .

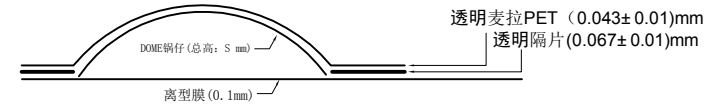

代号说明 Code description	
A	十字形 Cross
1D	下凸单点 1 dimple
DN	镀镍 Ni
J	散装包装 Bulk packing

序号 Item	产品型号 Product model	材料厚度 Materials T (mm)	动作荷重 Operating Force (g)	手感率 Click Ratio (%)	弹片高度 Height H (mm)	行程 Travel S (mm)	动作寿命 Operating life (cycles)
1	SD-X60A18-1D-DN-J	0.070	180±20	60±15	0.37±0.05	0.30±0.05	500000

this document is the property of Zigeng. It may not be reproduced without the prior written permission of the owner.

<p>邦斯达 BONS DA Electronics</p> <p>深圳市子庚科技有限公司</p>			图号 DWG NO	60A181DDNJ-000	
			三角法 TRIGONOMETRY		
核 准 APPROVED	王瑾雅	材 质 MAT.	SUS301	比例 SCALE	10:1
核 对 CHECKED		产 品 名 称 PRODUCT NAME	金属弹片 METAL DOME	单 位 UNIT	毫 米 MM
制 图 DRAWN	张鸿标	工 作 温 度 OPERATING TEMPERATURE	+105° -40°	版 次 No.REV.	A0
日 期 DATE	2024.01.13	储 存 温 度 DEPOSIT TEMPERATURE	+100° -55°	页 码 Page	1/1